

## Primary characteristics

The NAF wedge gate valve is an ideal solution for use in installations where medium class pressure applications are present. This valve offers very high corrosion resistance and extremely long life cycles and offer a high degree of reliability. The distinctive characteristic of this valve type include:

- Full bore
- Flexible wedge
- Rising stem
- Handwheel with bearing
- Sealing surfaces machined directly in the material of the body

**CE-marked** according to Pressure Equipment Directive (PED 97/23/EG) module H, category III

## Design

The valves have a rising stem, outside screw, and handwheel with stem nut mounted in needle thrust bearings. Full bore. Flexible guided wedge. Backseated stuffing box protects the packing in service. The seat facings are machined directly in the body and gate.

The bonnet of sizes DN 80—300 is in one piece. Sizes DN 350 and larger have a bolted yoke. The wedge gate valves can also include an actuator.

Contact NAF for further information about selection of electric actuators.

The design of connection flanges of various sizes of wedge gate valve is stated under "Connections" below.

## Applications

This type of valve is intended for shut-off applications with media that do not attack the material. The packing material of the valves is resistant to most acids and alkalis at temperatures up to 250°C.

## Connections

The valves are delivered with flanges with raised face acc. to PN 16 to the following standards for DN 80-500.

**(Table 1)**

NAF No.	Valves flanges drilled to	Counter flanges for welding
488310	EN1092	SS 2033 (DIN 2633)
DN 200 and larger can be supplied drilled for PN 10. When ordering, always state the required drilling for these DN sizes. The wedge gate valves are always supplied with flange diameters for pressure class PN 16.		
488200	EN1092	SS 2032 (DIN 2632)

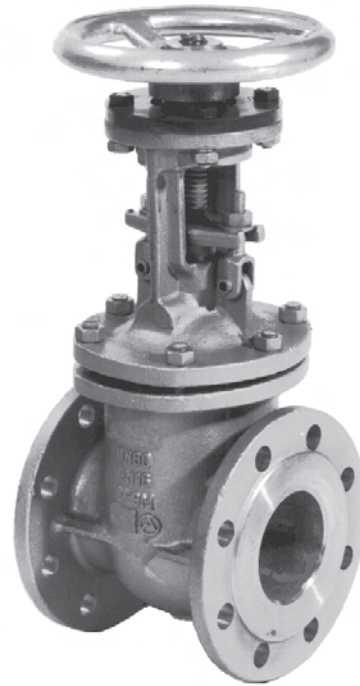

NAF 488310

## Capacities

The resistance factors (Z) below are given for fully open valves:

DN 80 — 500                      0,2

Max. dp without bypass valve:

DN 80 — 400                      16 bar

DN 500                                10 bar

## Working pressures and temperatures (Table 2)

Pressure rating	NAF No.	DN	Max. temperature °C					
			20	50	100	150	200	250
			Max. pressure bar (e)					
PN 10	488200	200-500	9,1	8,7	7,8	7,0	6,4	6,0
PN 16	488310	80-400	14,6	14	12,4	11,2	10,3	9,6

According to EN1092-1:2000

## Technical specification

Material: Stainless steel  
 Range of sizes: DN 80 — 400, PN 16  
 DN 200 — 500, PN 10  
 Pressure ratings: PN 10 and PN 16  
 Face-to-face: To DIN 3204 F4 and dimensions: SSG 1064 PN 10.  
 Connections: Flanges  
 Temperature range: Up to 250°C  
 Test pressure: 1.5 x PN valve open  
 1.1 x PN valve closed  
 Media water

**Materials (Table 3)**

Item No.	Part	Material
1	Handwheel	Nodular iron (DN 350 Steel)
2	Plate	Stainless steel EN 1.4436
3	Hex. screw	Stainless steel A4
4	Washer	Stainless steel
5	Hex. nut	Stainless steel A4
6	Bearing	Steel
7	Stem nut	Brass CW614N
8	Bonnet	Stainless steel EN 1.4408
9	Hex. nut	Stainless steel A4
10	Washer	Stainless steel
11	Gland	DN 80-150 EN 1.4571 DN 200-500 Stainless steel EN 1.4408
12	Eye bolt	Stainless steel A4
13	Stuffing box	PTFE
14	Box ring	PTFE/Glassfibre
15	Stud/Hex. screw	Stainless steel A4
16	Bonnet gasket	Reinforced graphite
17	Body	Cast stainless steel EN 1.4408
18	Stem	Cast stainless steel EN 1.4460
19	Wedge	Cast stainless steel EN 1.4470
20	Bonnet	Cast stainless steel EN 1.4408
21	Yoke bonnet	Cast stainless steel EN 1.4408
22	Stud	Stainless steel A4
23	Hex. nut	Stainless steel A4
24	Washer	Stainless steel

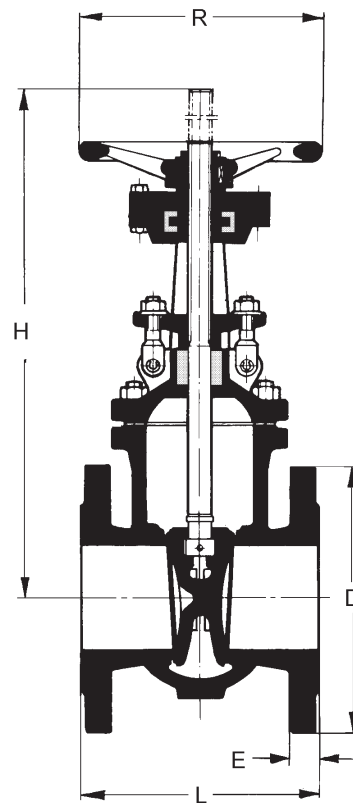
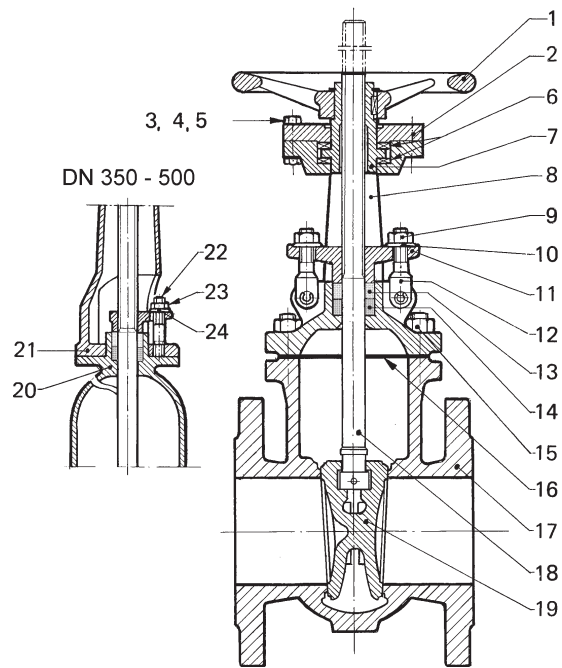

NAF 488200, 488310

**Dimensions and weight (Table 4)**

DN	Dimensions, mm					Number of wheel turns	Mass kg
	D	E	L	H*	R		
80	200	20	180	440	275	23	23
100	220	20	190	525	275	28	30
150	285	22	210	715	275	39	52
200	340	24	230	910	325	43	87
250	405	26	250	1100	325	53	117
300	460	28	270	1290	325	63	168
350	520	30	290	1545	630	62	220
400	580	32	310	1730	710	69	318
500	715	32	350	2070	710	74	500

\* Open valve